



PF-12^{Plus} Compact photometer

CONTENT

1. Safety precautions	30
1.1 General safety precautions	30
1.2 Chemical / biological safety	30
2. Compact photometer PF-12^{Plus}	31
2.1 Technical data	31
2.2 Design	32
2.3 Shipment	32
2.4 Interface and power supply	32
2.5 Operating environment	32
3. Usage	33
4. Setup	34
4.1 Unpacking the instrument	34
4.2 Operation with batteries	34
4.3 Operation with battery pack	34
5. Operation	35
5.1 Keypad	36
5.2 Configuration	36
5.3 Performance of <i>VISOCOLOR</i> [®] <i>ECO</i> tests	39
5.4 Performance of <i>NANOCOLOR</i> [®] tube tests	40
5.5 Basic photometric functions	41
6. Memory	42
6.1 Display memory	42
6.2 Search memory	42
6.3 Delete memory	42
6.4 Output memory	42
7. Special methods	43
7.1 User defined methods	43
7.2 Sample numbering	44
7.3 Identification of sample location	44
7.4 Sample dilution	45
7.5 Special methods	45
8. Sample preparation	46
9. Procedures for colored or turbid samples	47
9.1 Determination of correction values for <i>NANOCOLOR</i> [®] tube tests	47
10. Cleaning the instrument	50

11. Troubleshooting	50
12. Inspection equipment monitoring	50
13. Service	51
13.1 Spare parts and accessories.....	51
13.2 Disposal	51
13.3 Warranty	51
13.4 Contact	51

1. Safety precautions

1.1 General safety precautions

Please read the manual carefully and completely before setting up and using the instrument. Please adhere to all remarks. Not complying with this information may cause harm to the user or damage the instrument. In order not to compromise the instrument's safety measures, it may never be installed or used in any other way than described in this manual.

1.2 Chemical / biological safety

When using the instrument, it may be necessary to handle hazardous chemicals or biologically harmful samples. Please adhere to the following guidelines when using the instrument:

- Please read all information concerning hazards and safety measures in the material safety data sheets and on the packages of the compounds you work with.
- All used up compounds need to be disposed of in agreement with national rules and regulations.
- The type of safety equipment needs to be in line with the concentration and hazard potential of the given substance used.

2. Compact photometer PF-12^{Plus}

2.1 Technical data

Type:	Single-beam filter photometer with microprocessor control, self test and auto calibration
Wavelength range:	340–860 nm
Optics:	Automatic filter wheel with 7 interference filters, insensitive to external light for fast measurements without cuvette slot cover
Wavelengths:	345 / 436 / 470 / 540 / 585 / 620 / 690 nm plus 1 compartment for an additional filter 860 nm LED for NTU-Measurement
Wavelength accuracy:	± 2 nm Bandwidth at half of maximum transmission 10–12 nm
Light source:	Xenon lamp
Detector:	Silicon-photodiode
Blank value:	Automatic
Measuring modes:	Over 100 preprogrammed tests (<i>NANOCOLOR</i> [®] tube tests and <i>VISOCOLOR</i> [®] <i>ECO</i> tests), absorbance, transmission, factor, standard, turbidity, 50 freely programmable methods
Photometric range:	± 3 E
Photometric accuracy:	± 1 %
Stability:	< 0.002 E/h
Cuvette holder:	Round tubes 16 mm OD Data
memory:	1000 results, GLP-compatible
Display:	Backlit graphic display, 64 x 128 pixels, 12 languages; All important data at a glance: result with measuring unit, date, time, sample number, sample location, dilution
Operation:	Intuitive menu navigation, durable keypad, test selection via entering the test number or from parameter lists
Quality control:	With <i>NANOCONTROL</i> <i>NANOCHECK</i>
Interfaces:	USB B 2.0
Update:	Free of charge via Internet / PC
Operating range:	0–50 °C, up to 90 % relative humidity
Power supply:	USB-power supply, disposable or rechargeable batteries
Housing:	Water- and dustproof, IP 68
Dimensions:	215 x 100 x 65 mm
Weight:	0.7 kg
Warranty:	2 years



This device complies with the following directives:
2006/95/EC Low Voltage Directive
2004/108/EC EMC Directive

2.2 Design

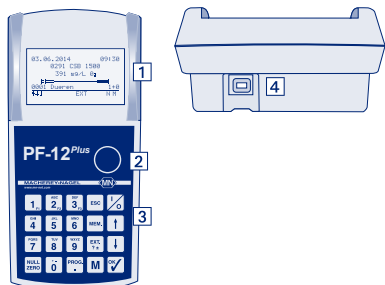

1. Graphic display 128 x 64 Pixels
2. Cuvette slot for tubes with 16 mm outer diameter
3. Keypad
4. USB-interface (2.0) for connection of power supply, charging the optional battery pack, data transfer and update

2.3 Shipment

If one of the components from the following list should be defective or missing, please contact MACHEREY-NAGEL or your local distributor.

Compact photometer PF-12^{Plus}

incl.: Software DVD, manual, 4 AA Mignon batteries, 4 empty cuvettes, funnel, beaker, syringe, USB-cable, calibration cuvette and certificate in a rugged case

2.4 Interface and power supply

USB-interface for:

- Update via Internet
- Data export to PC
- Power supply via PC USB-interface
- External power supply (REF 919 220) with USB-interface

Additional power supply:

- Batteries AA/ Mignon
- 4 rechargeable batteries (REF 919 221), rechargeable with additional charger
- Battery pack (REF 919 201), rechargeable via USB

2.5 Operating environment

The following conditions are necessary to provide longevity and flawless functioning of the instrument.

- Operating temperature 0–50 °C
- Relative humidity: up to 90 %
- To ensure safe results, the instrument should not be stored in extremely dusty, damp or wet conditions (the instrument optics are IP 68 proof and don't experience any sustained damage from such conditions).

Keep the instrument surface, cuvette slot and any accessories clean and dry. Splashes or spilled substances should be wiped away and cleaned immediately (see 10. *Cleaning the instrument*, page 50).

Important note: Protect the instrument from extreme temperatures (e.g. radiators, direct sun light and other heat sources).

3. Usage

As part of GLP, please familiarize yourself with all reagents used in your application. Read all product labels and MSDS before working with chemicals.

To ensure proper functioning of all inbuilt safety measures, the instrument may, under no circumstances, be used or installed in a different way than stated in the manual.

Only use the instrument as instructed to analyze MACHEREY-NAGEL tests. Please do not open the instrument or make any other unauthorized modifications. The instrument is a highly sensitive measuring device with high accuracy for the photometric evaluation of MACHEREY-NAGEL tests. Unauthorized modifications or opening the instrument in an inappropriate way can result in maladjustments of the instrument's optical components, or similar damage, which in turn can lead to wrong results.

Note: Due to the reasons stated above, MACHEREY-NAGEL declines any responsibility for the correct functioning of the instrument if it has been opened or used improperly and objects to any warranty claims made in such a case. MACHEREY-NAGEL's warranty and liability obligations as to product(s) or to any party on account thereof shall be void and of no effect if the product(s) or any part thereof have been subject to unauthorized change, abuse, misuse, accident or alteration, unauthorized application or installation not in compliance with the product(s) specifications as set forth in the product leaflets / instructions hereof ("unauthorized action") and such unauthorized.

4. Setup

4.1 Unpacking the instrument

Take the instrument out of the box and check for damage caused during shipment.

4.2 Operation with batteries

The PF-12^{Plus} photometer runs on 4 AA Mignon batteries (included in delivery). Rechargeable batteries, e.g. 4 NiMH AA 2500 mAh can be used in the instrument and are available as accessories (REF 919 221). The charger and rechargeable batteries need to be ordered separately. The battery status is displayed in the upper part of the display after switching on the device. When connected to a USB adapter, a “U” is displayed besides the battery symbol.

When changing batteries, we recommend to always exchange the entire set. The battery compartment is at the bottom of the instrument. To change the batteries, the cuvette slot has to be empty.

1. Turn the instrument around and place it on a soft surface.
2. Unscrew the screws of the battery compartment and take off the lid.
3. Insert the 4 batteries in the respective slots. Make sure polarity of batteries and slots match.
4. Put the lid back on, tighten the screws and turn the instrument around.

4.3 Operation with battery pack

The PF-12^{Plus} can be equipped with an internal battery pack, which can be charged via the USB port. The charging status of the internal battery pack is displayed in the upper part of the display in form of a small battery symbol with an “A”. When connected to a USB charger additionally a “L” is going to be displayed besides the battery symbol, indicating the ongoing charging process. You can order such a power pack separately and insert it into the instrument. Detailed installation instructions come with the battery pack.

5. Operation





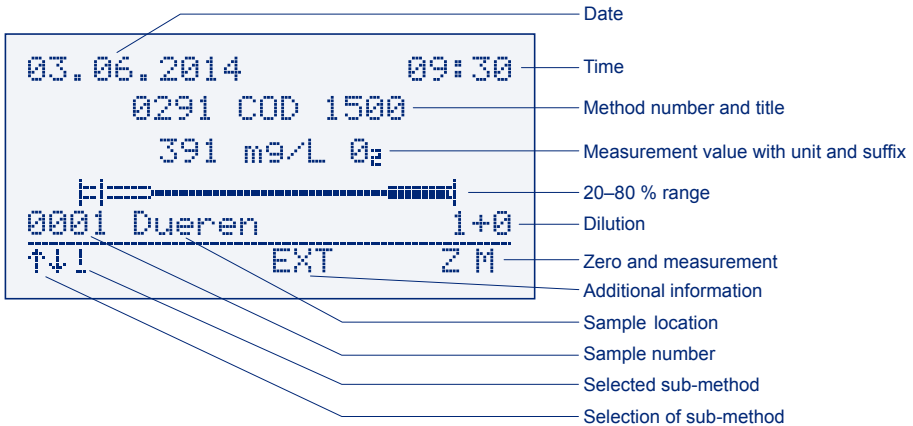









The PF-12^{Plus} is designed for easy handling and operation. The photometer PF-12^{Plus} has a 20-part keypad: 10 numbered keys and 10 keys with special functions.



The display is divided into three sections. In the upper part date, battery status and time are shown. Depending on the mode, in the middle section the actual measurement values, menu options or respective menu symbols are displayed. The lower part of the display is a task bar showing the possible options in the current mode.

Press **ESC** to return to the next higher level. Press **ESC** repeatedly to return to the method selection mode.

5.1 Keypad

Key 	On / Off switch
Keys 	For entering digits, letters, special characters
Keys 	Double-function keys, for sample number, location, dilution
Key 	For entering decimal points, to select special method
Key 	Abort, return to method selection
Key 	Scroll up
Key 	Scroll down
Key 	Enter, call up last result
Key 	Memory, call-up memory functions, store / not-store results
Key 	Absorbance program, recall the absorbance after measurement, estimated value and NTU value after measurement / selection of prefix
Key 	Manuell zero adjustment
Key 	Measurement, consecutive measurements are numbered continuously, call up last test

5.2 Configuration

To get to the configuration mode enter “900” in the method selection mode



or use  /  to select the entry “Settings” in the list and press  to confirm.

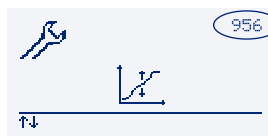

Additionally there is a quick start option. Every setting has its own three-digit number which can be entered in the start menu to directly access each menu.

The configuration menu is based on icons. You can navigate through the menu via  / , confirm by pressing  and follow the instructions on the display.

5.2.1 Language (Method 954)



Select the desired language via  /  and press  to confirm.

5.2.2 Time (Method 951)



Select the digits via  /  and adjust via keypad. Press  to confirm. Select the desired time format via  /  and press  to confirm.

5.2.3 Date (Method 950)



Select the digits via / and adjust via keypad. Press to confirm. Select the desired date format via / and press to confirm. The following format types are available:

23.01.2014

01/23/2014

2014-01-23

5.2.4 Contrast (Method 959)



Use / to adjust the display contrast in different gradation. Press to confirm.

5.2.5 Brightness (Method 960)



Use / to adjust the display brightness in different gradation. Press to confirm.

5.2.6 Calibration (Method 956)



Press to start the calibration. The instrument asks to make sure there is no cuvette in the slot. Press to confirm. Afterwards the PF-12^{Plus} asks you to insert the calibration tube (clean test tube filled with distilled water). Confirmation with starts the water calibration.

5.2.7 Reaction time (Method 952)



Use / to turn the reaction time on or off and press to confirm.

5.2.8 Signal tone (Method 961)



Use / to turn the signal tone on or off and press to confirm.

5.2.9 20–80 % range (Method 957)



Use / to turn the 20–80 % range on or off and press to confirm. When enabled, the 20–80 % range will be displayed at every measurement and provides information on where the result lies in relation to the measurement range. Is the mark in the thick part of the beam, the result is out of the 20–80 % range. In this case the sample either has to be diluted or a test kit with a different measurement range has to be used.

5.2.10 Turbidity control (NTU-Check) (Method 958)



Use / to turn the turbidity control on or off and press to confirm. You can enter an individual NTU limit using the keypad. If this function is turned on, parallel to each measurement the nephelometric turbidity of the sample is determined and stored. If the turbidity is exceeding your selection, an exclamation mark is displayed next to the measurement value. Press to display the NTU value.

5.2.11 Filter 8



Enter the wavelength of the special filter using the keypad and press to confirm. This configuration can only be performed in the service mode. To calibrate the special filter press and confirm with . Press to reset the settings.

5.2.12 AUTO-OFF (Method 953)



Use / to adjust the AUTO-OFF time. Five different settings are possible: Off (the instrument is never turned off automatically), 5 min (factory setting), 10 min, 15 min, 20 min, 60 min. Press to confirm.

5.2.13 SYSTEM-RESET



This configuration can only be made in the service mode. After an additional security confirmation, the photometer performs a SYSTEM-RESET, thus restoring the state of delivery. The display then asks for a calibration.

5.2.14 PROG. UPDATE (Method 955)



In order to perform a program update, you must first install the update software and the new program file (www.mn-net.com) on your computer. Before you start the update procedure the photometer has to be connected to your computer via the USB-interface. The photometer should be recognized automatically. If not, activate the update-mode manually. Therefore confirm the program update with . After a successful update the photometer restarts.

5.2.15 Calibration adjustment (Method 962)



The PF-12^{Plus} device is provided with the MACHEREY-NAGEL factory calibration and can be readily used without any need for user calibration. The calibration adjustment tool can be used to meet regulatory requirements. Therefore the factory-provided calibration of the VISOCOLOR[®] ECO and NANOCOLOR[®] methods can be adjusted with a standard in the menu “calibration adjustment”. The parameter including submethod to be adjusted is chosen via the four digit entry mask (e.g. 0291 for COD 1500 100–1500 mg/L). Place the tube with the zero value or the reagent blank into the cuvette slot of the PF-12^{Plus} and press to start the zero measurement. Subsequently place the tube with the standard into the device and press to start the measurement. Enter the desired value for the standard with the keypad and confirm your entry with (Note: The entered value must be within the measurement range of the respective submethod, otherwise the entry will not be adopted). The changed calibration will be stored automatically and will be executed the next time the concerned method will be chosen. The changed calibration will be indicated in form of a star behind the respective test name. When stored, the results measured with an adjusted calibration will be indicated with a star, too. The calibration adjustment can be deleted and set back to factory calibration by pressing in the same menu. The measurement values in the memory will not be affected by the reset.

We recommend to use the factory-provided calibration and not to change this one. The calibration can be adjusted to meet regulatory requirements. For the calibration adjustment procedure we recommend to use a standard with a value located in the upper third of the measurement range to reduce the calibration error to a minimum.

5.3 Performance of VISOCOLOR[®] ECO tests

Instead of the VISOCOLOR[®] ECO measuring tube, a clean, dry 16 mm OD round tube is used. Zero is adjusted with a second round tube (depending on the test either an untreated sample or a reagent blind value).



Switch on the photometer

The display “Method __ _” appears.

A VISOCOLOR[®] ECO test can be selected via the test number (5 - xx)

or

using / via the list.



Perform a zero measurement

Insert the clean round tube with the blank value into the photometer and press . Remove the round tube with the blank value.

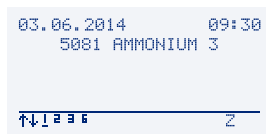

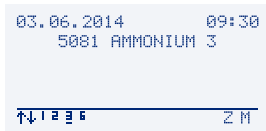

Perform a measurement

Insert the clean round tube with the measurement solution into the photometer and press **M**. Read the result.

For the detailed procedure of the individual tests please follow the corresponding instruction leaflet. You can find detailed descriptions and pictograms on our homepage www.mn-net.com/PF-12Plus, and on the software DVD.

5.4 Performance of NANOCOLOR® tube tests

The characteristics of all our NANOCOLOR® tube tests are stored in the PF-12^{Plus}. The measurement of a blank value is only necessary for a few tests.



Switch on the photometer

The display "Method __ _" appears.

A NANOCOLOR® tube test can be called up by entering the test number (0 - xx)

or

by pressing **↑**/**↓** via the list.



Perform a zero measurement (for few tests)

Insert the clean round tube with the blank value into the photometer and press **NULL ZERO**. Remove the round tube with the blank value.

Perform a measurement

Insert the clean round tube with the measurement solution into the photometer and press **M**. Read the result.



Change of the submethod

A submethod change (e.g. for determination of the result in another unit) can be done by pressing the buttons **↑**/**↓** in the measurement menu of the chosen test. The currently active submethod is indicated by the underlined number in the taskbar. After choice of the desired submethod, the measurement range of the submethod will be displayed briefly. After change of the submethod, please perform the measurement again to display the result. For some tests only one submethod is programmed.

For the detailed procedure of the individual tests please follow the corresponding instruction leaflet. You can find detailed descriptions and pictograms on our homepage www.mn-net.com/PF-12Plus, and on the software DVD.

5.5 Basic photometric functions





```
Method#
- 901 FACTOR
  902 STANDARD
  903 EXTINCTION
  905 TRANSMISSION
-----
↑↓
```

By calling up method **901–903** and **905–906** you can access basic photometric functions or select the required option in the scroll mode by using  / .





Method 901: Measurement with factor

Select the desired wavelength using  /  and confirm with , enter the factor via keypad and confirm with . Perform the measurement by following the instructions on the display. Return to the method selection by pressing . The factor will be erased.





Method 902: Measurement with standard

Select the desired wavelength using  /  and confirm with , enter the standard concentration via keypad and confirm with . Perform the measurement by following the instructions on the display. Return to the method selection by pressing . The standard concentration will be erased.

Method 903: Measurement of extinction



Select the desired wavelength using  /  and confirm with , perform the measurement by following the instructions on the display. Return to the method selection by pressing .

Method 905: Measurement of transmission

Select the desired wavelength using  /  and confirm with , perform the measurement by following the instructions on the display. Return to the method selection by pressing .

Method 906: Measurement of nephelometric turbidity

Perform the measurement by following the instructions on the display. Return to the method selection by pressing .

The turbidity calibration can be performed via this menu and is started by pressing . One after the other the turbidity solutions from the test kit *NANOCONTROL NANOTURB* (REF 925 702) are put into the photometer and measurement is started with . After the calibration is finish it can be confirmed with .

6. Memory

In the standard mode of operation the memory is activated. All measurement data are stored in the PF-12^{Plus}. Stored data can be transferred to a PC using the free-of-charge MACHEREY-NAGEL data export software. The PF-12^{Plus} allows the user to search the memory and select specific data.



The icon based memory menu is accessed by pressing in the  method selection mode. The icons have the following meaning and function:







6.1 Display memory



Confirm the icon “Display memory” with . Scroll through the data sets with  / .

6.2 Search memory



Confirm the icon “Search memory” with . Select data with a specific date, location or method number. Confirm with . Select the option “Find” with  /  and confirm with  to start the search. If no criteria are defined, the complete memory is shown and you can scroll through the data sets with  / . When leaving this menu the search criteria are deleted.

6.3 Delete memory



The complete memory is deleted. This happens after an additional security check which has to be confirmed with .

6.4 Output memory



The data can be transferred to a terminal program via the USB port of the PF-12^{Plus} by selecting this icon and confirming with .

7. Special methods

7.1 User defined methods

The PF-12^{Plus} allows the user to program up to 50 user-defined methods. These methods can be defined as linear (with one factor) or non-linear (functions up to the fourth degree + Ln-functions). For these methods all options as for the pre-programmed methods are available, e.g. location, date, dilution, data storage.



Select

Press to enter the special method menu from the method selection menu.

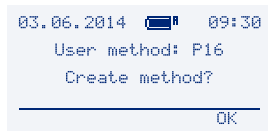

Create

With and for example 16 method P16 is selected. If this method doesn't exist yet, confirm with to create it.

Follow the instructions in the display to edit the characteristic of the new method. Enter filter, factor, digits, etc. via the keypad.

Enter the factors (F0 to F4, FLn) according to the formula $y = F0 + F1xE^1 + F2xE^2 + F3xE^3 + F4xE^4 + FLn \times LnE$. By pressing prior input of the factor the prefix is changed.

Changes made in error can be changed at any time using /. The menu can be left at any time by pressing .

If the selected method already exists, different options are possible which can be selected via /.

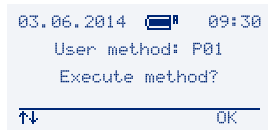

Execute

Press to execute the selected method.

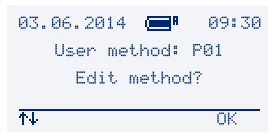

Edit

Press to change the characteristics of the method.



Delete

After an additional security check the method is deleted by pressing .

To create and manage user defined methods one can also use the free-of-charge *NANOCOLOR*[®] data export software from MACHEREY-NAGEL. This can be downloaded via www.mn-net.com/PF-12Plus. Further information can be found in the software manuals under the same link.

7.2 Sample numbering

To differentiate between samples, the PF-12^{Plus} assigns a sample number to every measurement (starting with 0001). Subsequent measurements are numbered accordingly. You have the option to change the sample number after every measurement and to assign it to the current result. To do so, press **F1** before the next measurement. An entry option appears to enter the 4 digit sample number via the keypad. Once you have entered the sample number, it is displayed together with all other sample information at the bottom of the display. The following measurements are then automatically numbered. The sample numbering is carried out on the basis of a daily counter. With each new day the PF-12^{Plus} starts to count with the sample number 0001 and counts upwards for each further measurement.

7.3 Identification of sample location

To differentiate between sampling locations, you have the option to enter a sample location after performing a measurement (up to 12 characters). Press button **F2** to open the entry option for the sample location. Once you have entered the sample location, it is displayed together with all other sample information at the bottom of the display. The sample location is added to the result in the memory automatically. If you have entered additional sample locations before, you can press **F2** to choose or edit the sample location from a list of up to 20 previously defined sample locations with the buttons **↑**/**↓**. For editing the sample places choose the appropriate entry with the **↑**/**↓** buttons and replace the existing letters with the keypad. Deleting single digits can be accomplished by typing the button “1” two times.

7.4 Sample dilution

During chemical analyses samples often have to be diluted to fit within a certain measuring range. To avoid manual calculations, you can enter the dilution into the PF-12^{Plus}, which will then re-calculate the result, taking the dilution into account.

Example:

Expected result: between 80 and 200 mg/L

Measuring range photometer: 0.1–10.0 mg/L

Necessary dilution: (200 → 10 mg/L): at least 1:20 (1+19)

Recommended dilution: 1:25 to 1:50 to get within the middle of the measuring range

Dilutions are entered as 1 part sample plus x parts distilled water as to create distinct readings. You can enter dilutions between 1+1 and 1+999.

Press **F3** before the next measurement to open the entry option for the dilution. The screen for entering the dilution appears. Once you have entered the dilution, it is displayed together with all other sample information at the bottom of the display. The result is immediately re-calculated using the entered dilution.

Note: The entered dilution only impacts the current result. In the case of large dilutions, e.g. 1+999, it is possible that the result is displayed in a different dimension as to enable proper display in the screen.

7.5 Special methods

Besides the MACHEREY-NAGEL NANOCOLOR[®] and VISOCOLOR[®] ECO test kits, the PF-12^{Plus} is also equipped with preprogrammed special methods.

```
Method:
- Special methods
  Settings
  Basic functions
  Tube tests
-----
↑↓
```

These can be chosen via the list entry “Special methods“ with the buttons **↑/↓**. Confirming with **☑** starts the chosen method.

8. Sample preparation

Water samples are not always suitable for immediate analysis. In case of heavily polluted water (or waste water) especially, it is often not possible to conduct analysis without pre-treating the sample first; otherwise, larger concentrations of organic or inorganic compounds can interfere and lead to false negative or false positive test results.

Some of the following preparations may be necessary before analyzing the water (examples in parentheses):

1. Dissolve undissolved compounds (metal oxides)
2. Release complex or adsorptive compounds (hexacyanoferrates)
3. Decompose polymer compounds (polyphosphates)
4. Change the state of oxidation (Cr(III) → Cr(VI))
5. Remove interfering substances (nitrite in the case of nitrate determination)
6. Separate the substance to be determined by distillation (ammonium, cyanide)
7. Eliminate organic substances (waste water)
8. Filter turbid and suspended matter (sedimentation); e.g. with membrane filters

MACHEREY-NAGEL offers a number of methods for sample pre-treatment:

The crack set (REF 918 08) and NANOCOLOR® NanOx are used for oxidative treatment of samples in an acidic medium under normal pressure at 100–120 °C. These methods are easy to handle and solve a large number of decomposition problems.

For samples with difficult matrices, but especially for rapid determination of total nitrogen, total phosphorus and total chromium, we recommend oxidative decomposition with NANOCOLOR® NanOx at elevated pressures in a microwave oven.

Very resistant samples (applicable to points 1, 2, 3, and 7) can be treated by wet decomposition (oxidation) with nitric and sulfuric acid:

Instructions: Add 50 mL of sample, 2 mL nitric acid (65%) and 2 mL sulfuric acid (96%) to a beaker, heat almost to dryness (use fume cupboard with fan on). As soon as a white SO₃-fog appears, stop heating and allow the deposit to cool down to room temperature, then add 20 mL distilled water. Neutralise with sodium hydroxide solution and pour sample into a volumetric flask 50 mL, rinse out the beaker twice with 10 mL distilled water each time and pour into the volumetric flask. Then fill the volumetric flask to the 50 mL mark with distilled water. Almost all metals can be determined directly from this solution.

Depending on the specific problems, this method has to be adjusted or replaced by another sample preparation method. Always keep in mind that after the sample preparation has been completed, a defined volume of sample has to be present. This is critical to make an accurate statement with regards to the concentration once the actual analysis has been performed. However, it is also highly important to re-establish the sample's original chemical milieu (pH value, redox potential, etc.) according to the specific analytical requirements of the specific analysis method.

As can be deduced from this brief explanation, each analysis has to be treated individually and the sample prepared accordingly in case of polluted samples. Only thus accurate and realistic test results can be achieved. Please contact MACHEREY-NAGEL should you have any questions.

For detailed instructions for the different decomposition methods and their applicability please consult the respective instruction leaflet.

9. Procedures for colored or turbid samples

These procedures can only be used in connection with the corresponding original instructions in this **NANOCOLOR®** manual.

The photometric analysis of water samples with inherent color or turbidity always requires determination of a correction value. Color and turbidity causes increased light absorption (increased extinction), thus leading to wrong results. Determination of correction values requires individual procedures for every test.

For example, it is not possible simply to measure the color of the sample without reagents and then subtract this value from the test result. In many cases, the reagents alter the color or turbidity of the sample. All changes of the sample during analysis, such as dilution or addition of chemicals which alter pH or redox state have to be taken into account. Only the main reagent, which forms the measured color complex, is not added.

With the **NANOCOLOR® PF-12^{Plus}**, the measurement program for the correction value is started after the measurement of the (turbid or colored) sample (value A) by pressing . The instrument asks for the cuvette with the correction value (value B) and measures the correction. The corrected measurement result is displayed and stored. For some tests it is necessary to measure an additional blank value.

Basic procedure:

Determine measuring result as per original instruction = A

Determine correction value as per special instruction = B

Analytical result = A – B

Exceptions: Methods, where decreasing extinctions are measured against a reagent blank value.

In these cases, analytical result = A + B

The corresponding analytical instructions point out this fact.

It is very important to subtract only values with equal dimensions (e.g. mg/L N; mg/L NH₄; mmol/m³; E).

If, in the same matrix, the correction factor for several samples is so low that it can be neglected, it may be possible to work without correction. However, this conclusion can only be drawn from practical experience and cannot be predicted!

9.1 Determination of correction values for **NANOCOLOR®** tube tests

For measurement of the correction value use a clean, empty test tube filled with distilled water as a blank value (exceptions: test 0-59 / 0-64 / 0-65 / 0-66).

Test	Test tube for correction (value B)
0-03, 0-04, 0-05, 0-06, 0-08 Ammonium 3–200	Proceed as described in the instructions for test 0-03 / 0-04 / 0-05 / 0-06 / 0-08, but do not add NANOFIX R2 , close, mix.
0-07 AOX 3	Almost all colors and turbidities are destroyed under test conditions and do not interfere. Resistant colors and turbidities cause deviating results which cannot be circumvented.
0-09 Lead 5	The original test contains a correction.
0-14 Cadmium 2	Fill empty test tube with 4.0 mL sample, add 0.2 mL R2, close and mix.
0-15 Carbonate hardness 15	Open carbonate hardness test tube, add 4.0 mL sample solution, close, mix and adjust to zero (value B). Open test tube, add R2, close and shake well. Measure after 2 min (analytical result = A – B).
0-17 Chlorine/Ozone 2 0-18 Chlorine dioxide 5	Fill empty test tube with 4.0 mL sample for each test.



Test	Test tube for correction (value B)
0-19 Chloride 200	Open chloride test tube, add 1.0 mL sample solution and 1.0 mL distilled water, close, mix.
0-21 Chlorid 50	Open chloride test tube, add 4.0 mL sample solution and 1.0 mL distilled water, close, mix.
0-24 Chromate 5	Fill empty test tube with 4.0 mL sample, add 0.2 mL R2, close, mix.
0-11, 0-12, 0-22, 0-23, 0-26, 0-27, 0-28, 0-29, 0-30, 0-33, 0-36, 0-38 COD 40–60000	Almost all colors and turbidities are destroyed under test conditions and do not interfere. COD resistant colors and turbidities cause deviating results which cannot be circumvented.
0-31 Cyanide 08	Proceed as described in the instructions for test 0-31, but add 0.5 mL distilled water instead of 0.5 mL R3.
0-32 Anionic surfactants 4	Proceed as described in the instructions for test 0-32, but instead of 0.5 mL R2 add 0.5 mL distilled water.
0-34 Cationic surfactants 4	Proceed as described in the instructions for test 0-34, but instead of 0.5 mL R2 add 0.5 mL distilled water.
0-35 DEHA 1	Open DEHA test tube, add 4.0 mL sample, close and mix.
0-37 Iron 3	No correction possible.
0-40 Fluoride 2	No correction possible.
0-41 Formaldehyde 8	Open formaldehyde test tube, add 2.0 mL sample solution, close and mix.
0-43 Hardness 20	Open hardness test tube, add 0.2 mL sample solution, close and mix.
0-44 Hardness Ca /Mg	No correction possible.
0-45 Potassium 50	Open potassium test tube, add 2.0 mL sample solution, close and mix.
0-46 Formaldehyde 10	Fill empty test tube with 2.0 mL distilled water, 2.0 mL sample solution and 1.0 mL R2, close and mix.
0-47 Nonionic surfactants 15	No correction possible.
0-49 Silver 3	Proceed as described in the instructions for test 0-49, but add 0.5 mL DMSO instead of 0.5 mL R3.
0-50 Organic acids 3000	Proceed as described in the instructions for test 0-50, but instead of 2.0 mL R5 add 2.0 mL distilled water.
0-52 Compl. agents 10	Fill empty test tube with 4.0 mL sample and 1.0 mL distilled water, close and mix (analytical result = A + B).
0-53 Copper 5	Proceed as described in the instructions for test 0-53, but add 0.1 mL DMSO instead of 0.1 mL R2.
0-54 Copper 7	Fill empty test tube with 4.0 mL sample and 0.4 mL distilled water, add 0.2 mL R2, close and mix.
0-56 Molybdenum 40	No correction possible.
0-57 HC 300	The original test contains a correction.
0-58 Manganese 10	Fill empty test tube with 4.0 mL sample solution, 0.5 mL distilled water and 0.5 mL R2, close and mix. Add 1 measuring spoon R3, close and shake vigorously.
0-59 total Chromium 2	Almost all colors and turbidities are destroyed under test conditions and do not interfere. For samples which are still colored or turbid after decomposition: Fill empty test tube with 4.0 mL sample solution.
0-61 Nickel 7	Proceed as described in the instructions for test 0-61, but instead of 1.0 mL R2 add 1.0 mL NaOH 14 %.
0-64, 0-65 Nitrate 8–50	Open nitrate test tube, add 0.5 mL sample and 0.5 mL 2-propanol, close, mix. <u>Blank value for correction:</u> Open nitrate test tube, add 0.5 mL distilled water and 0.5 mL 2-propanol, close, mix.

Test	Test tube for correction (value B)
0-66 Nitrate 250	Open nitrate test tube, add 0.2 mL sample and 0.5 mL 2-propanol, close, mix. <u>Blank value for correction:</u> Open nitrate test tube, add 0.2 mL distilled water and 0.5 mL 2-propanol, close, mix.
0-68 Nitrite 2	Fill empty test tube with 4.0 mL sample, add 0.2 mL R2, close, mix.
0-69 Nitrite 4	Open nitrite test tube, add 4.0 mL sample solution, close, mix.
0-70 POC 200	Proceed as described in the instructions for test 0-70, but instead of 1.0 mL R2 add 1.0 mL distilled water.
0-71 Nickel 4	Proceed as described in the instructions for test 0-71, but instead of 1.0 mL R2 add 1.0 mL NaOH 14%.
0-72 pH 6.5–8.2	The original test contains a correction.
0-73 Sulfide 3	Fill empty test tube with 0.5 mL sulfuric acid 50 %, add 1 measuring spoon R2 and 4.0 mL sample solution, close and shake gently. Add 200 µl R3, close, mix.
0-74 Phenolic index 5	Proceed as described in the instructions for test 0-74, but do not add NANOFIX R2 , close, mix.
0-55, 0-76, 0-80, 0-81 ortho- and total Phosphate 1–45	Proceed as described in the instructions for test 0-55 / 0-76 / 0-80 / 0-81 but instead of R4 add 0.2 mL distilled water, close, mix.
0-79 ortho- and total Phosphate 50	Proceed as described in the instructions for test 0-79, but instead of R3 add 1.0 mL sulfuric acid 20 %, close, mix.
0-82 Oxygen 12 8-22, 8-25 BOD5	The original tests contain a correction.
0-83, 0-88, 0-92 total Nitrogen TN _b 22 / 60 / 220	Almost all colors and turbidities are destroyed under test conditions and do not interfere. For samples which are still colored or turbid after decomposition, correction values are determined as described above for test 0-64.
0-84 Residual hardness 1	Open Residual hardness test tube, add 5.0 mL sample solution, close and mix.
0-85 Starch 100	No correction possible.
0-86 Sulfate 200 0-87 Sulfate 1000	The original test contains a correction.
0-89 Sulfite 10	Open sulfite test tube, add 4.0 mL sample and 0.2 mL distilled water, close and mix.
0-90 Sulfite 100 Anal.result = A + B	Fill empty test tube with 0.2 mL R2, 4.02mL sample solution and 1.0 mL distilled water, close, mix.
0-91 Thiocyanate 50	Fill empty test tube with 4.0 mL sample.
0-93, 0-94, 0-99 TOC 25–600	The original tests contain a correction.
0-96 Zinc 4	Fill empty test tube with 4.0 mL sample, add 0.2 mL R2, close and mix.
0-97 Tin 3	Proceed as described in the instructions for test 0-97, add 1.0 mL ethanol instead of R4.
0-98 Aluminum 07	Proceed as described in the instructions for test 0-98, add 0.5 mL distilled water instead of R3.
8-38 Ethanol 1000	Open ethanol test tube, add 4.0 mL R1 and 0.5 mL sample solution (consider dilution), mix, add 2 drops R3, close and mix.
8-59 Methanol 15	Open methanol test tube, add 3.0 mL R1 and 1.5 mL sample solution (consider dilution), mix, add 2 drops R3, close and mix.
8-71 Peroxide 2	Fill empty test tube with 4.0 mL sample.

10. Cleaning the instrument

Clean the housing of the instrument with a damp cloth. Wipe away splashes as soon as possible. Clean and dry the cuvette slot with a soft cotton tissue. Generally, tubes and photometer always need to be kept clean. Clean the tubes with a lint-free cloth.

11. Troubleshooting

Error message	Cause	Solution
AD-overflow	Too much light at detector	<ul style="list-style-type: none">• Please contact MACHEREY-NAGEL for calibration
	Deviation between air-blank and expected value, $dE > \pm 10 \text{ }^\circ\text{C}$ or $dE > \pm 10 \text{ mE}$	<ul style="list-style-type: none">• Remove tube• Press  if no tube is in the cuvette slot
Display stays dark	No power supply	<ul style="list-style-type: none">• Check if batteries / rechargeable batteries are inserted or USB-cable is plugged in
Instrument is turned on but doesn't react	Instrument crashed	<ul style="list-style-type: none">• Turn instrument off, wait 10 s, turn instrument on

The correction of problems, which can occur with the PF-12^{Plus} photometer are limited to the above mentioned errors in the table, changing the battery or the rechargeable battery and the calibration of the device.

The user must not conduct any other maintenance; there are no other parts, which can be changed at the point of interest. Opening the device will cause loss of the warranty claim.

12. Inspection equipment monitoring

The photometric accuracy of the PF-12^{Plus} can be tested with the colored *NANOCONTROL* *NANOCHECK* solutions (REF 925 701), provided by MACHEREY-NAGEL. The appropriate evaluation sheet is attached to the inspection equipment or can be downloaded on our homepage www.mn-net.com.

13. Service

13.1 Spare parts and accessories

Description	REF
Robust case with foam inlay for PF-12 ^{Plus} , accessories and VISOCOLOR® ECO Test kits	934 102
Calibration tube	916 908
USB cable for data export and power supply	919 390
Optional rechargeable battery pack	919 391
Reaction tubes (20; 16 mm OD)	916 80
Manual	919 392
VISOCOLOR® ECO test instructions for PF-12 ^{Plus}	934 001

13.2 Disposal



In compliance with local and national legal regulations (EU Directive 2011/65/EU), the MACHEREY-NAGEL company disposes old instruments free of charge.

Note: With effect from August 2005, disposal using public waste disposal facilities is no longer permitted. In the case of disposal, please contact your MACHEREY-NAGEL representative.

13.3 Warranty

The warranty period is 24 months. The original commercial invoice serves as the warranty card and must be presented in case of a claim during the given period. The warranty is not valid in cases of improper handling and the warranty does not cover defects caused by the external power supply. The warranty is limited to repairs of defective parts or, in our sole discretion, replacement with a brand new and defect-free instrument. Any warranty claims made or alleged do not influence the total warranty period of 24 months. The right of withdrawal does not exist. Further claims are excluded and these especially include claims for compensation caused by direct or indirect damages. Additionally our current Terms and Conditions for the Sale of Goods as printed on price lists shall apply.

13.4 Contact

MACHEREY-NAGEL GmbH & Co. KG
Neumann-Neander-Str. 6–8
52355 Düren
Germany
Tel.: +49 24 21 969-0 · Fax: +49 24 21 969-199
info@mn-net.com · www.mn-net.com

Your competent partner in analytical chemistry

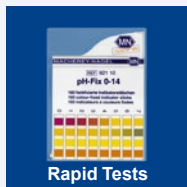

Tradition and Modernity – 100 years experience

- Worldwide operating German company (founded 1911)
- Subsidiaries in France, Switzerland and USA
- Distributors in over 150 countries
- Development, production and sales of special products for water, environmental and food analysis, for biotechnology, chemical and pharmaceutical industry and medical diagnostics



**Investment in the future –
New building in Düren for Research & Development, production and warehouse**

Service

- Technical support by our Customer Service Center
- Product-specific quality certificates and Material Safety Data Sheets
- Customized special products
- Easy ordering and short delivery times
- Large number of catalogs, flyer and product information – of course free of charge

Contact

Technical support and customer service

Filtration, Rapid Tests, Water Analysis: +49 24 21 969-340
+49 24 21 969-187
+49 24 21 969-161
+49 24 21 969-138
+49 24 21 969-190
+49 24 21 969-174
csc@mn-net.com

Your local distributor:



Envitech Ltd

Unit S7
Capital Business Park
Parkway
Cardiff
CF3 2PU

Email: info@envitech.co.uk

Tel: 0044 2920 364252
Web: www.envitech.co.uk

www.mn-net.com

MACHEREY-NAGEL



MACHEREY-NAGEL GmbH & Co. KG · Neumann-Neander-Str. 6-8 · 52355 Düren ·

Germany
and international:
Tel.: +49 24 21 969-0
Fax: +49 24 21 969-199
E-mail: info@mn-net.com

Switzerland: Germany
MACHEREY-NAGEL AG Tel.: +41 62 388 55 00 Fax: +41 62 388 55 05
E-mail: sales-ch@mn-net.com

France:
MACHEREY-NAGEL EURL
Tel.: +33 388 68 22 68 Fax: +33 388 51 76 88
E-mail: sales-fr@mn-net.com

